

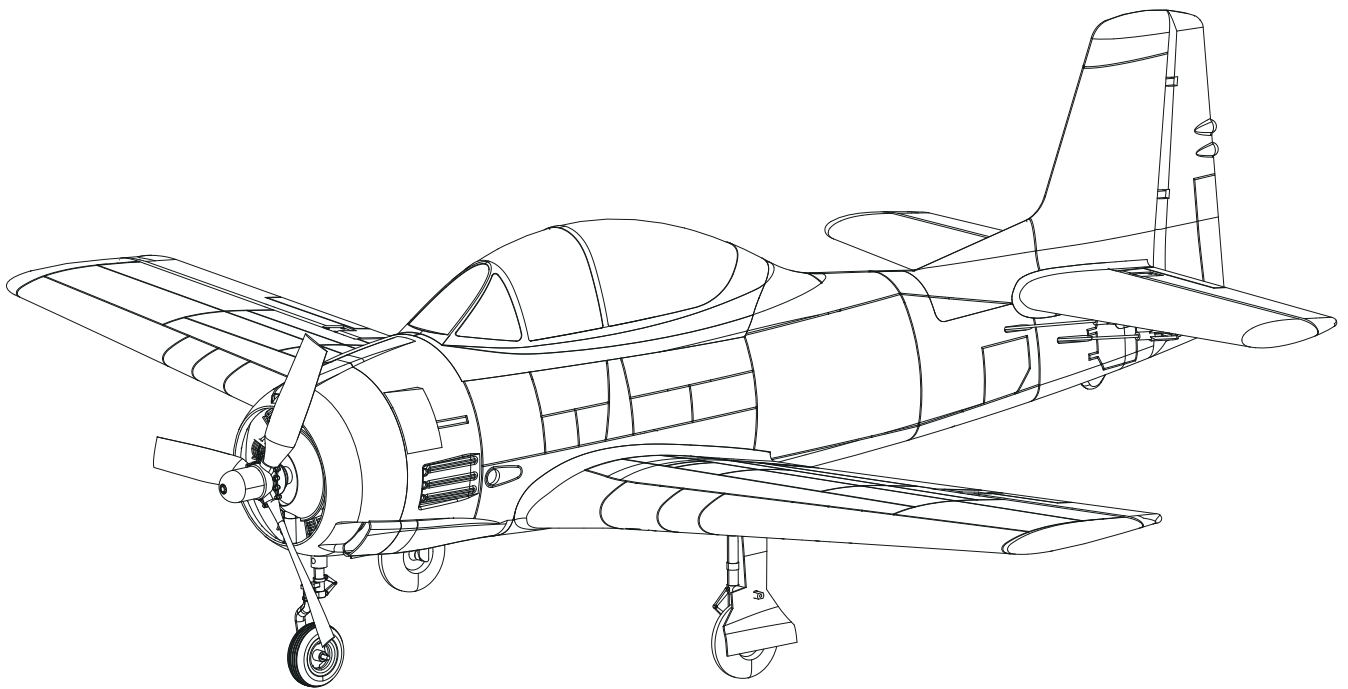

# 800MM T-28



MAN-G0235

Instruction Manual  
操作手册

**SIMPLE**  
• SIMPLE ASSEMBLY

**ROBUST**  
• STRONG DURABLE EPO

**STABLE**  
• SMOOTH FLYING PERFORMANCE

**FMSHOBBY.COM**

**WARNING**

**WARNING:** Read the ENTIRE instruction manual to become familiar with the features of the product before operating. Failure to operate the product correctly can result in damage to the product, personal property and cause serious injury.

This is a sophisticated hobby product and NOT a toy. It must be operated with caution and common sense and failure to do so could result in injury or damage to the product or other property. This product is not intended for use by children without direct adult supervision.

This manual contains instructions for safety operation and maintenance. It is essential to read and follow all the instructions and warnings in the manual prior to assembly, setup or use, in order to operate and avoid damage or serious injury.

**Safety precautions and warnings**

As the user of this product, you are solely responsible for operating in a manner that does not endanger yourself and others or result in damage to the product or the property of others. This model is controlled by a radio signal subject to interference from many sources outside your control. This interference can cause momentary loss of control so it is advisable to always keep a safe distance in all directions around your model, as this margin will help avoid collisions or injury.

Age Recommendation: Not for children under 14 years. This is not a toy.

- Never operate your model with low transmitter batteries.
- Always operate your model in an open area away from cars, traffic or people.
- Avoid operating your model in the street where injury or damage can occur.
- Never operate the model in populated areas for any reason.
- Carefully follow the directions and warnings for this and any optional support equipment you use (chargers, rechargeable battery packs, etc.)
- Keep all chemicals, small parts and anything electrical out of the reach of children.
- Moisture causes damage to electronics. Avoid water exposure to all equipment not specifically designed and protected for this purpose.
- Never lick or any place of any your model in your mouth as it could cause serious injury or even death.

**Safety****Lithium Polymer (Li-Po) Battery Warning**

**CAUTION:** Always follow the manufacturer's instructions for safe use and disposal of batteries. Fire, property damage, or serious injury can result from the mishandling of Li-Po batteries.

- By handling, charging or using a Li-Po Battery you assume all risks associated with lithium batteries.
    - If at any time the batteries begin to swell or balloon, discontinue use immediately!
  - Always store the batteries at room temperature in a dry area to extend the life of the battery. Always transport or temporarily store the battery in a temperature range of 40-120F. Do not store the battery or model in a car or in direct sunlight. If stored in a hot car, the battery can be damaged or even catch fire.
  - Never use a Ni-Mh Charger to charge Li-Po Batteries. Failure to charge the battery with a Li-Po compatible charger may cause fire resulting in personal injury and property damage.
  - Never discharge Li-Po Cells below 3V.
  - Never leave charging batteries unattended.
  - Never charge damaged batteries.
- Charging the Flight Battery Warning**
- Use a battery charger that is designed to safely charge the Li-Po Battery. Read the charger instructions carefully before use. When charging the battery, make certain the battery is on a heat resistant surface. It is also highly recommended to place the Li-Po Battery inside a fire resistant charging bag readily available at hobby shops or online.

## Introduction

After World War II, countries around the world began to design mid-level trainer aircraft with higher engine power, faster flight speed and more advanced cockpit equipment, for use by pilots when they transitioned from primary trainer aircraft to jet aircraft. The T-28 trainer is one of them. Compared with its peers, its engine power is larger, and it was the first to adopt tricycle landing gear, so that its flight speed and takeoff and landing handling characteristics are more like those of jet aircraft. The T-28 two-seat single-engine trainer is a piston-type intermediate trainer produced by North American Airlines. It was the last generation of piston trainers produced by the United States. It served in the US Air Force and the US Navy in the early 1950s.

The T-28 restores the maneuverability and high stability of this trainer as much as possible within the constraints of the small size (0.8m). High-rate low-density EPO foam provides high speed and aerobic flight support and improves overall durability. The factory-equipped high-efficiency KV1700 motor and high-performance 20A ESC, when paired with the recommended 2S 1300mAh battery, can easily complete a variety of maneuvering actions. The convenient size allows it to be flown in large parks and sports fields and transported easily without disassembly.

This is a fun little plane, and a great addition to the hanger. Even for more experienced pilots, she is an excellent choice for daily flying.

### Key Features:

- Scale fuselage details, prop and spinner
- Powerful FMS KV1700 outrunner motor
- Reinforced main landing gear and steerable nose gear
- Made of durable EPO foam

## Table of contents

Introduction .....	3
Kit contents .....	3
Model assembly .....	4
Battery installation .....	7
Receiver diagram .....	7
Get your model ready to fly .....	7
Clevis installation .....	8
Control horn and servo arm settings .....	9
Center of gravity(CG) .....	9
Before flying the model .....	9
Flying course .....	10
Troubleshooting .....	11
Spare parts list content .....	11

## Kit contents

Before assembly, please inspect the contents of the kit. The diagram opposite details the contents of the kit with labels. If any parts are missing or defective, please identify the name or part number (refer to the spare parts list near the end of the manual) then contact your local shop or email us: support@fmsmodel.com

### Specifications

Wing span: 800mm / 31.5in

Overall length: 670mm / 26.3in

Flying weight: ~ 470g

Motor size: 3015-KV1700

Wing load: 44.3g/dm<sup>2</sup> (0.087oz/in<sup>2</sup>)

Wing area: 10.6 (164.2sq.in)

ESC: 20A

Servo: 9g Servo x 4

Recommended battery: Li-Po 7.4V 1300mAh 20C

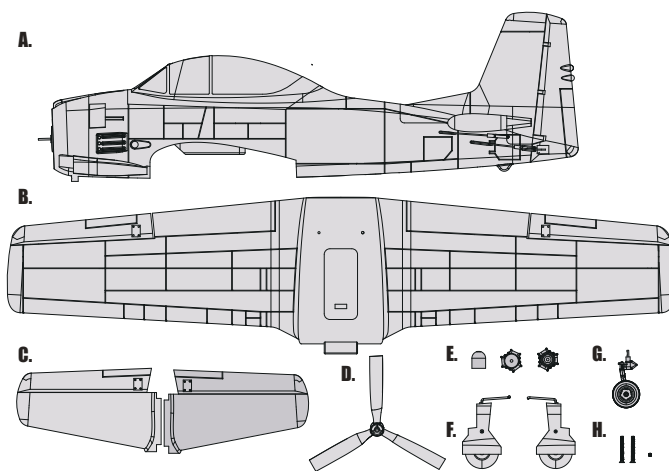

- A: Fuselage
- B: Main wing set
- C: Horizontal stabilizer
- D: Propeller
- E: Spinner
- F: Main landing gear set
- G: Front landing gear set
- H: Screw Set

## Model assembly

### Mainwing installation

1. With the bottom of the fuselage facing up, apply mainwing to fuselage as shown.

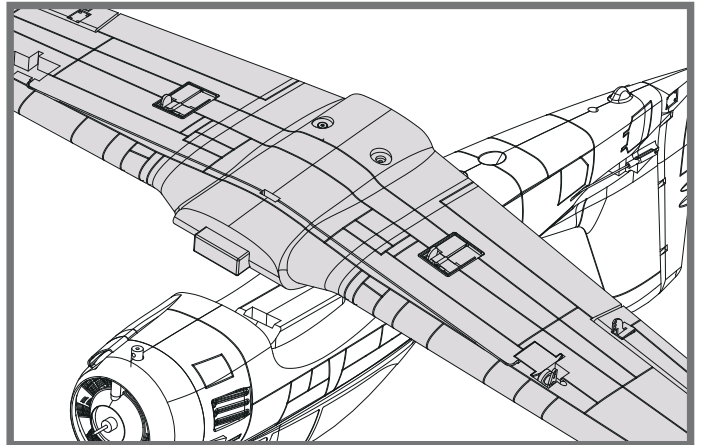

2. Ensure that the mounting holes of the mainwing and the fuselage are aligned, and secure the mainwing to the fuselage using the attached screws HKM3.0\*32mm.

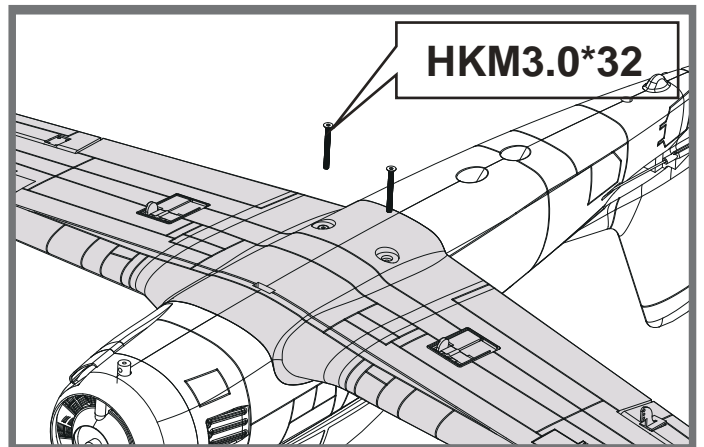

### Horizontal stabilizer installation

1. Apply foam-safe glue to the horizontal tails as shown in the figure, align the left and right horizontal tails and push them into the slots at the rear of the fuselage.  
Note: Ensure the control horn faces down as shown.

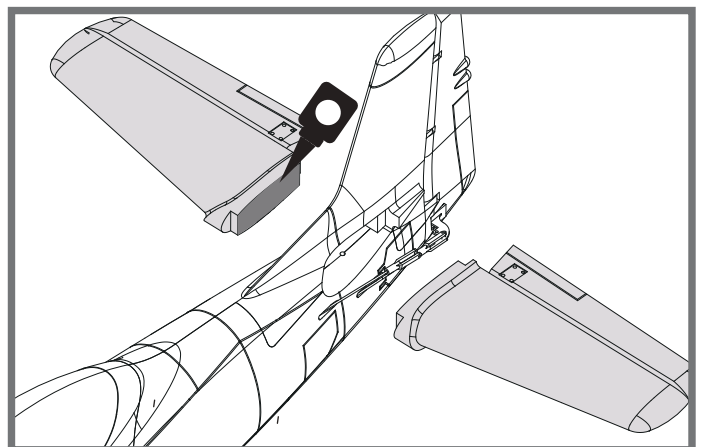
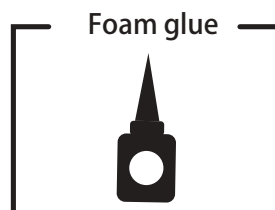

## Model assembly

2. Make sure the elevator servo is in the neutral position. Install the control arms to servo, the clevis to elevator control horns.

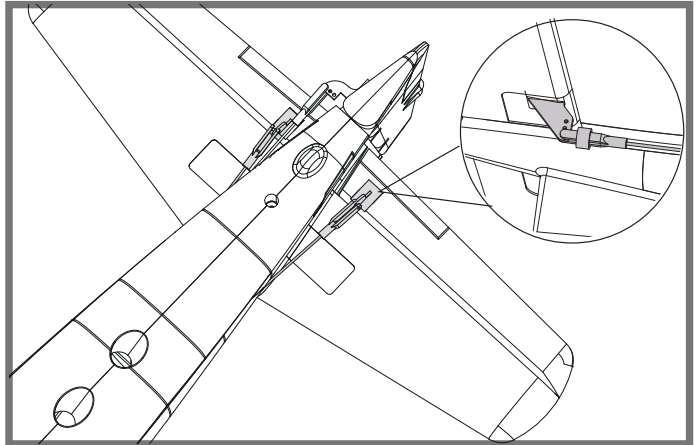

### Main landing gear installation

1. Release the latch of the landing gear base at the bottom of the main wing, align the main landing gear steel wire and insert it into the hole of the base as shown in the figure (do not reverse the left and right landing gears).
2. Lock the base latch, the main landing gear installation is completed.

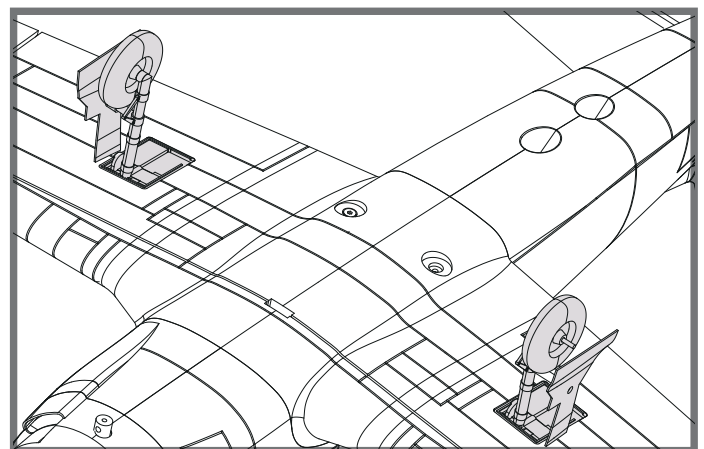
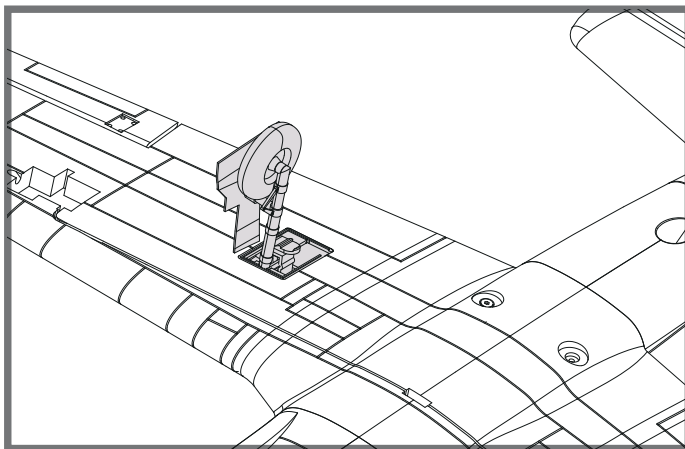
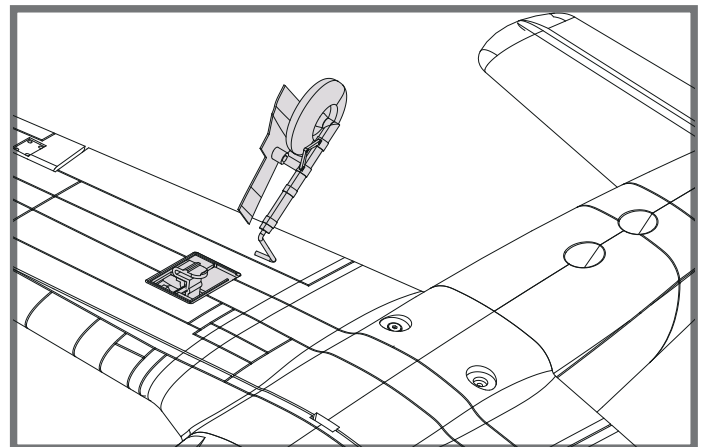

### Nose landing gear installation

Insert the nose landing gear into the corresponding slot at the bottom of the fuselage as shown in the figure and tighten it with set screw 3\*3.

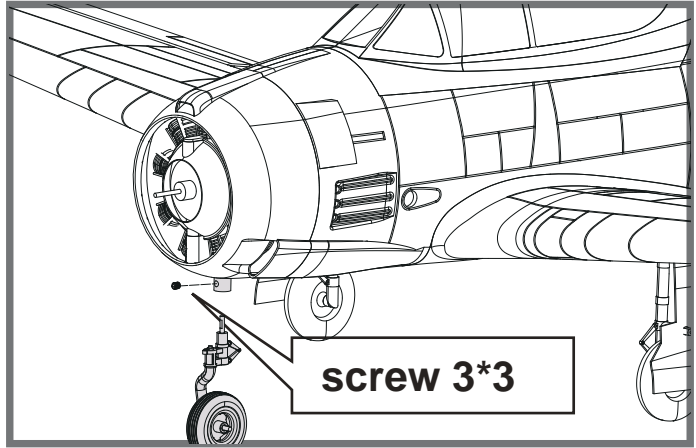

---

### Propeller installation

1. Install the spinner backplate, propeller, prop washer and spinner adapter.
2. Tighten the spinner adapter until the propeller is securely fastened.

Note: The rotation direction of the motor should be clockwise (rear view)  
Disassemble in reverse order.

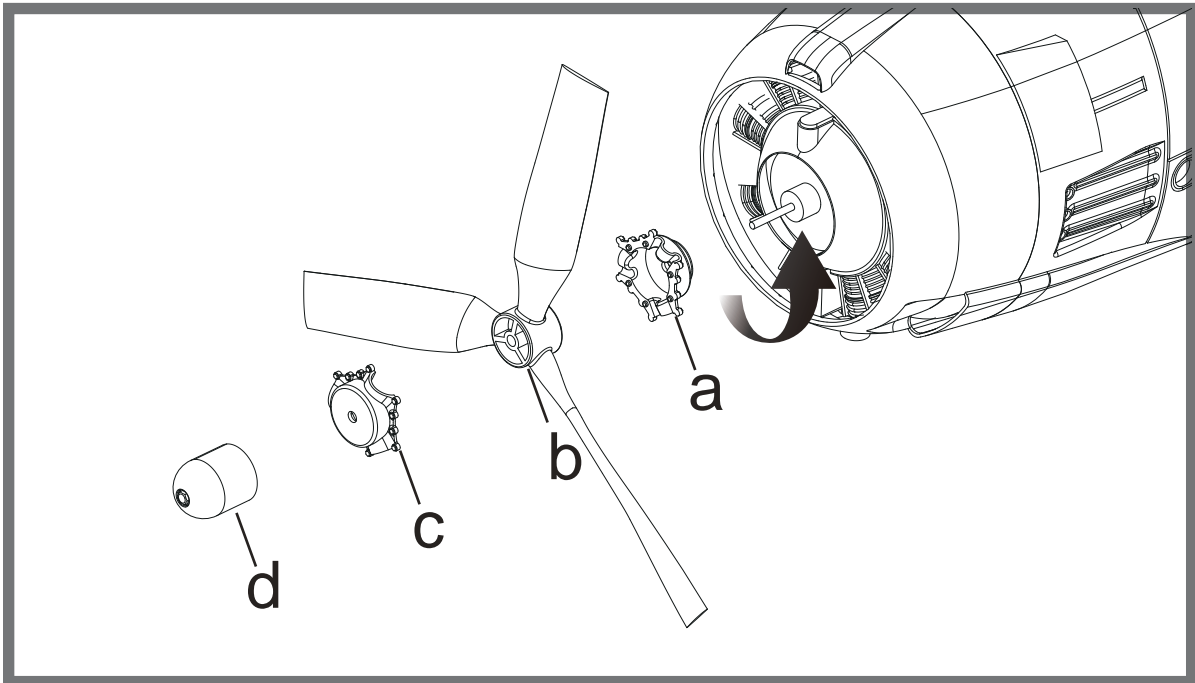

## Battery installation

1. Pull back on the latch and remove the battery hatch.
2. Apply the hook tape to the cable end of the battery.
3. Slide the fully charged battery into the battery compartment with the power supply cable toward the rear end of the plane.

Note: The center of gravity can be adjusted by moving the battery forward or aft. Having the correct center of gravity is critical to achieving proper flight characteristics.

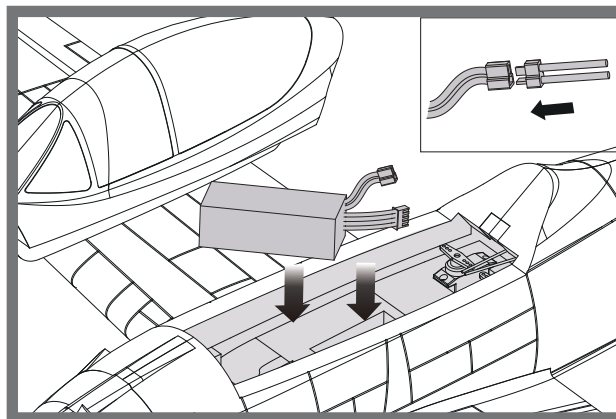

## Receiver diagram

The cables from the servo connector board should be connected to your receiver in the order shown. Note that the LEDs can be powered by any spare channel on the receiver. Tuck the wire leads into the recessed cavity towards the rear of the battery hatch.

		Receiver
Aileron	1	Channel-1 — Aile
Elevator	2	Channel-2 — Elev
Throttle	3	Channel-3 — Thro
Rudder	4	Channel-4 — Rudd
Gear	5	Channel-5 — Gear
Spare	6	Channel-6 — Spare

## Get your model ready to fly

### Important ESC and model information

1. The ESC included with the model has a safe start. If the motor battery is connected to the ESC and the throttle stick is not in the low throttle or off position, the motor will not start until the throttle stick is moved to the low throttle or off position. Once the throttle stick is moved to the low throttle or off position, the motor will emit a series of beeps. Several beeps with the same tune means the ESC has detected the cells of the battery. The count of the beeps equals the cells of the battery. The motor is now armed and will start when the throttle is moved.
2. The motor and ESC come pre-connected and the motor rotation should be correct. If for any reason the motor is rotating in the wrong direction, simply reverse two of the three motor wires to change the direction of rotation.
3. The motor has an optional brake setting. The ESC comes with brake switched off and we recommend that the model be flown with the brake off. However, the brake could be accidentally switched on if the motor battery is connected to the ESC while the throttle stick is set at full throttle. To switch the brake off, move the throttle stick to full throttle and plug in the motor battery. The motor will beep one time. Move the throttle stick to low throttle or the off position. The motor is ready to run and the brake will be switched off.
4. Battery Selection and Installation. We recommend the Li-Po 7.4V 1300mAh 20C Li-Po battery. If using another battery, the battery must be at least a Li-Po 7.4V 1300mAh 20C battery. Your battery should be approximately the same capacity, dimension and weight as the Li-Po 7.4V 1300mAh 20C Li-Po battery to fit the fuselage without changing the center of gravity significantly.

## Get your model ready to fly

### Transmitter and model setup

Before getting started, bind your receiver with your transmitter. Please refer to your transmitter manual for proper operation. **CAUTION:** To prevent personal injury, **DO NOT** install the propeller assembly onto the motor shaft while testing the control surfaces. **DO NOT** arm the ESC and do not turn on the transmitter until the Transmitter Manual instructs you to do so. **Tips:** Make sure all control sticks on your radio are in the neutral position (rudder, elevator, ailerons) and the throttle is in the OFF position. Make sure both ailerons move up and down (travel) the same amount. This model tracks well when the left and right ailerons travel the same amount in response to the control stick. Move the controls on the transmitter to make sure the aircraft control surface moves correctly. See diagrams.

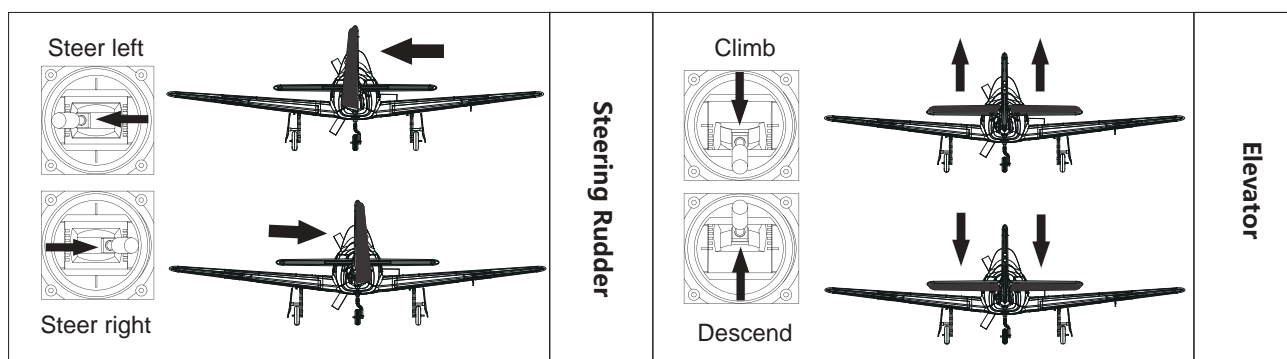
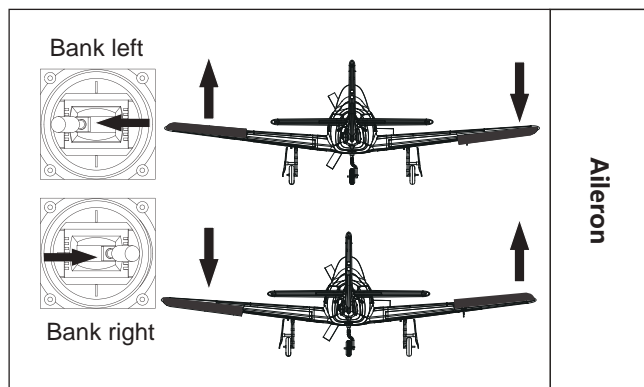

### Control throws

The suggested control throw setting for this airplane are as follows (dual rate setting):

Tips: On the first flight, fly the model in low rate. The first time you use high rates, be sure to fly at low to medium speeds. High rate, as listed, is only for EXTREME maneuvering.

	High Rate	Low Rate
Elevator	16mm up / down	12mm up / down
Aileron	14mm up / down	10mm up / down
Rudder	22mm left / right	16mm left / right





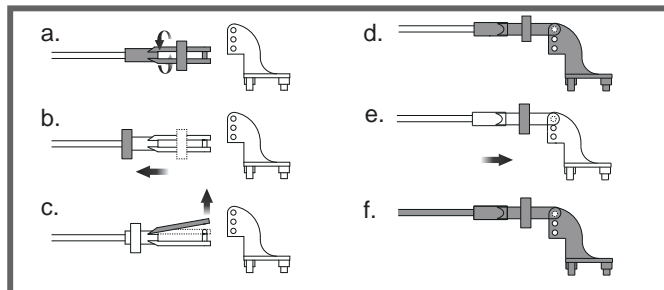

### Clevis installation

1. Pull the tube from the clevis to the linkage.
2. Carefully spread the clevis, then insert the clevis pin into the desired hole in the control horn.
3. Move the tube to hold the clevis on the control horn.

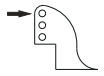

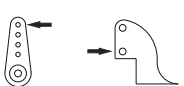
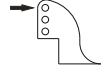
## Control horn and servo arm settings

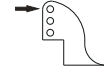
The table shows the factory settings for the control horns and servo arms. Fly the aircraft at the factory settings before making changes. After flying, you may choose to adjust the linkage positions for the desired control response.

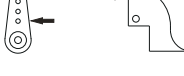
	Horns	Arms	More control throw
Elevator			
Rudder			Less control throw
Ailerons			

## Check the C.G. (Center of gravity)

When balancing your model, adjust the battery as necessary so the model is level or slightly nose down. This is the correct balance point for your model. After the first flight, the CG position can be adjusted for your personal preference.

1. The recommended Center of Gravity (CG) location for your model is 45mm from the leading edge of the main wing (as shown) with the battery pack installed. Mark the location of the CG on top of the wing.

2. When balancing your model, support the plane at the marks made on the bottom of the main wing with your fingers or a commercially available balancing stand. This is the correct balance point for your model. Make sure the model is assembled and ready for flight before balancing.

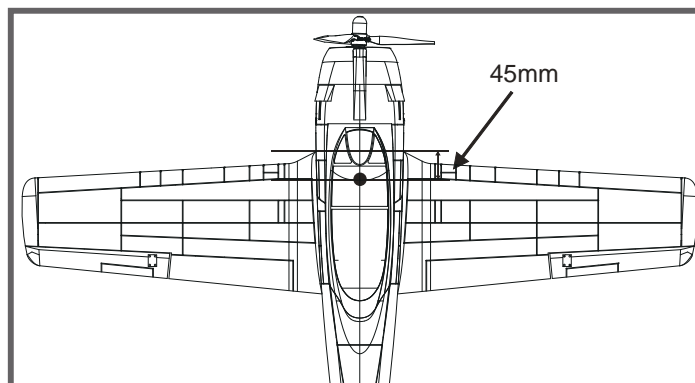

## Before flying the model

### Find a suitable flying site

Find a flying site clear of buildings, trees, power lines and other obstructions. Until you know how much area will be required and have mastered flying your plane in confined spaces, choose a site which is at least the size of two to three football fields - a flying field specifically for R/C planes is best.

Never fly near people - especially children, who can wander unpredictably.

### Perform the range check for your plane

As a precaution, an operational ground range test should be performed before the first flight each time you go out. Performing a range test is a good way to detect problems that could cause loss of control such as low batteries, defective or damaged radio components, or radio interference. This usually requires an assistant and should be done at the actual flying site you will be using.

First turn on the transmitter, then install a fully-charged battery into the fuselage. Connect the battery and install the hatch. Remember, use care not to bump the throttle stick. Otherwise, the propeller/fan will turn and possibly cause damage or injury.

**Note:** Please refer to your Transmitter Manual that came with your radio control system to perform a ground range check. If the controls are not working correctly or if anything seems wrong, do not fly the model until you correct the problem. Make certain all the servo wires are securely connected to the receiver and the transmitter batteries have a good connection.

## Before flying the model

### Monitor your flight time

Monitor and limit your flight time using a timer (such as on a wristwatch or in your transmitter if available). When the batteries are getting low you will usually notice a performance drop before the ESC cuts off motor power, so when the plane starts flying slower you should land. Often (but not always) power can be briefly restored after the motor cuts off by holding the throttle stick all the way down for a few seconds. To avoid an unexpected dead-stick landing on your first flight, set your timer to a conservative 4 minutes. When your alarm sounds you should land right away.

## Flying course

### Take off

While applying power, slowly steer to keep the model straight. The model should accelerate quickly. As the model gains flight speed you will want to climb at a steady and even rate. It will climb out at a nice angle of attack (AOA).

### Flying

Always choose a wide-open space for flying your plane. It is ideal for you to fly at a sanctioned flying field. If you are not flying at an approved site always avoid flying near houses, trees, wires and buildings. You should also be careful to avoid flying in areas where there are many people, such as busy parks, schoolyards, or soccer fields. Consult laws and ordinances before choosing a location to fly your aircraft. After takeoff, gain some altitude. Climb to a safe height before trying technical manoeuvres, including high speed passes, inverted flight, loops, and point rolls.

### Landing

Land the model when you hear the motor pulsing (LVC) or if you notice a reduction in power. If using a transmitter with a timer, set the timer so you have enough flight time to make several landing approaches. The model's three point landing gear allows the model to land on hard surfaces. Align model directly into the wind and fly down to the ground. Fly the airplane down to the ground using 1/4-1/3 throttle to keep enough energy for proper flare. Before the model touches down, always fully decrease the throttle to avoid damaging the propeller or other components. The key to a great landing is to manage the power and elevator all the way to the ground and set down lightly on the main landing gear. After a few flights you will find the model can be set down lightly on the mains and you can hold the nose wheel off balancing the model on the mains until it slows and gently settles the nose.

### Maintenance

Repairs to the foam should be made with foam safe adhesives such as hot glue, foam safe CA, and 5min epoxy. When parts are not repairable, see the Spare Parts List for ordering by item number. Always check to make sure all screws on the aircraft are tightened. Pay special attention to make sure the spinner is firmly in place before every flight.

## Trouble shooting

Problem	Possible Cause	Solution
Aircraft will not respond to the throttle but responds to other controls.	-ESC is not armed. -Throttle channel is reversed.	-Lower throttle stick and throttle trim to lowest settings. -Reverse throttle channel on transmitter.
Extra propeller noise or extra vibration.	-Damaged spinner, propeller, motor or motor mount. -Loose propeller and spinner parts. -Propeller installed backwards.	-Replace damaged parts. -Tighten parts for propeller adapter, propeller and spinner. -Remove and install propeller correctly.
Reduced flight time or aircraft underpowered.	-Flight battery charge is low. -propeller installed backward. -Flight battery damaged.	-Completely recharge flight battery. -Replace flight battery and follow flight battery instructions.
Control surface does not move, or is slow to respond to control inputs.	-Control surface, control horn, linkage or servo damage. -Wire damaged or connections loose.	-Replace or repair damaged parts and adjust controls. -Do a check of connections for loose wiring.
Controls reversed.	Channels are reversed in the transmitter.	Do the control direction test and adjust controls for aircraft and transmitter.
-Motor loses power -Motor power pulses then motor loses power.	-Damage to motor, or battery. -Loss of power to aircraft. -ESC uses default soft Low Voltage Cutoff(LVC).	-Do a check of batteries, transmitter, receiver, ESC, motor and wiring for damage(replace as needed). -Land aircraft immediately and recharge flight battery.
LED on receiver flashes slowly.	Power loss to receiver.	-Check connection from ESC to receiver. -Check servos for damage. -Check linkages for binding.

## Spare parts list content

FMSPA101RED-1	Fuselage	FMSPROP038	Propeller
FMSPA102RED-1	Main Wing Set	FMSDIX012	Motor mount
FMSPA103RED-1	Horizontal Stabilizer	PRKVX1700-1	3015-KV1700 motor
FMSPA104RED	Cockpit	PRESC004	20A ESC
FMSPA105	Spinner	FMSSER005	9g digital gear servo positive
FMSPA107RED	Cowl	FMSSER011	9g digital servo 54 degree
FMSPA108RED	Main landing gear set		
FMSPA109RED	Front landing gear set		
FMSPA110	Linkage rods		
FMSPA112RED	Decal sheet		

**警告**

警告：在组装、调整及飞行前请务必认真阅读产品说明书以熟知产品的特性。请严格按照说明书提示进行飞机的组装、调整及飞行。如操作不当会造成产品本身损坏及其它财产损失，甚至造成严重的人身伤害。

声明：模型不是玩具，具有一定的危险性，操作者需要具备一定的飞行经验，初学者请在专业人士指导下操作。禁止十四岁以下儿童操作、飞行。

**安全须知**

本产品飞行由无线电遥控器控制，在飞行过程中可能会受到外界强信号干扰而导致失控，甚至坠机。因此，在飞行过程中务必始终与飞机保持一定的安全距离，避免意外碰撞、受伤。

- 请勿在发射器电池低电量的情况下操纵模型飞机。
- 请勿在公路、人群、高压线密集区、机场附近及其它法律法规明确禁止飞行的场合飞行。
- 请勿在雷雨、大风、大雪或者其它恶劣气象环境下飞行。
- 请严格遵照产品指导说明及安全警告操作本产品及其相关配置（例如充电器、电池等）。
- 请勿将相关化工类产品、零部件、电子部件等置于儿童可触及的范围。
- 请勿将电子件暴露于潮湿的环境中，以免造成损坏。
- 请勿将本品任意处置于口中，以免造成人身伤亡。

**锂聚合物电池使用安全须知**

- 使用锂聚合物电池时，须严格遵守制造商说明、要求并了解相关风险，使用不当会导致锂聚合物电池起火，从而造成严重的财产损失甚至人身伤害。
- 禁止使用变形、胀气的锂聚合物电池。
- 禁止使用过充、放电的锂聚合物电池，避免发生危险。长时间不使用须将锂聚合物电池放电至存储电压（3.8~3.85V / 节）。锂聚合物电池须储存在室内干燥区域（4.5~48.5°C），禁止将锂聚合物电池置于阳光下暴晒或车内，高温可能会导致锂聚合物电池起火，造成财产损失和人身伤害。
- 请使用专用充电器对锂聚合物电池进行充放电，禁止使用其它如：镍氢电池充电器。充放电时，禁止将锂电池放置于高温物体表面，建议使用锂电池防爆袋。不正确的充放电操作会对锂聚合物电池造成损伤，甚至会引起火灾，造成财产损失和人身伤害。
- 禁止将锂聚合物电池单节电压放至低于 3V，禁止给已损坏的锂聚合物电池充电。
- 锂聚合物电池充放电须在有人看管的情况下进行，避免发生意外造成不必要的损失。

**飞机电池充电警告：**

请确保使用合格的电池充电器给锂电池充电。在使用充电器前，请认真阅读充电器说明书。充电过程中，请确保把电池置于耐热的表面。建议把锂电池置于防火充电袋内充电，防火充电袋可在相关模型实体店或网上买到。

## 产品特点

第二次世界大战之后，各国开始设计发动机功率较大、飞行速度较快和座舱设备比较先进的中级教练机，供飞行学员从初级教练机向喷气式飞机过渡训练时使用。T-28型教练机就是其中之一，与同辈相比，它的发动机功率大，而且率先采用了前三点式起落架，以便其飞行速度和起飞、着陆的操纵特点更接近于喷气式飞机。T-28“特洛伊”双座单发教练机，是北美航空公司生产的活塞式中级教练机，它是美国生产的最后一代活塞式教练机，在20世纪50年代初服役于美国空军和美国海军。

T-28在0.8M小尺寸的限定条件下力所能及地还原这款教练机的易操控性和高安定性。轻质耐用的高倍率低密度EPO泡沫材料给高速飞行和特技飞行提供保障，并提高整体的耐用性。高转速KV1700电机、高性能20A电调，搭配2S 1300mAh电池，可轻松完成各种机动动作。便携的尺寸使它可以在大公园或运动场飞行，并且无需拆卸即可轻松运输。

她是一架小而有趣的飞机，即便对于飞行经验较为丰富的飞行员来说，她也是日常飞行的优选之一。

特征：

- 1.像真机身细节、螺旋桨和桨罩
- 2.动力充足的KV1700无刷电机
- 3.坚固耐用的主起落架和可转向前起落架
- 4.轻质耐用的EPO泡沫材质

## 产品组成

在组装产品之前，请仔细检查以下配件，如有缺失或者损坏，请及时联系当地店面或者邮件至厂家（support@fmsmodel.com），告知缺失或损坏的配件名称及编码（请在本说明书尾页查看相应的配件编码）。请注意，不同配置，包装盒内部物品不同。

### 产品参数

翼展:800mm(31.5in)

机身长: 670mm (26.3in)

飞行重量: 大约470g

电机: 无刷3015-KV1700

翼载荷:44.3g/dm<sup>2</sup> (0.087oz/in<sup>2</sup>)

翼面积: 10.6 (164.2sq.in)

电调: 20A

舵机: 9g x 4

推荐电池: 7.4V 1300mAh 20C

## 目录

产品特点 .....	13
产品组成 .....	13
机体安装 .....	14
电池安装 .....	17
接收机连接示意图.....	17
遥控器设置 .....	17
夹头安装方式 .....	18
舵角和舵机摇臂安装.....	18
重心调整 .....	19
飞行前准备 .....	19
故障检修指导.....	20
配件列表 .....	20

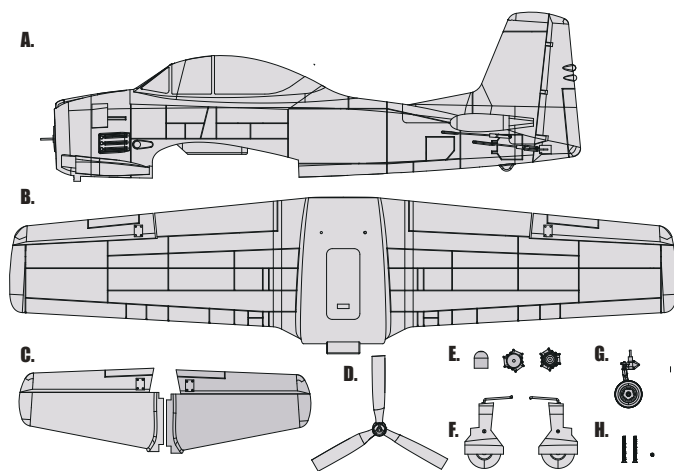

- |        |         |
|--------|---------|
| A: 机身  | F: 主起落架 |
| B: 主翼  | G: 前起落架 |
| C: 平尾  | H: 螺丝组  |
| D: 螺旋桨 |         |
| E: 桨罩组 |         |

## 机体安装

### 主翼安装

1.如图所示，保持机身底部朝上，将主翼安装至机身。

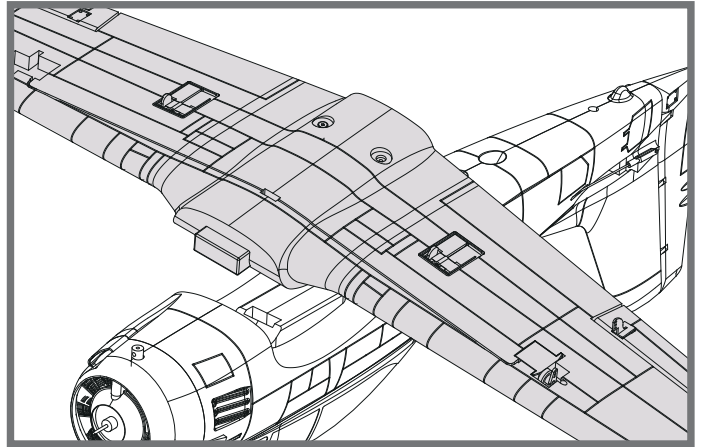

2.确保机翼与机身安装孔位对齐，使用所附螺丝HKM3.0\*32mm固定机翼至机身。

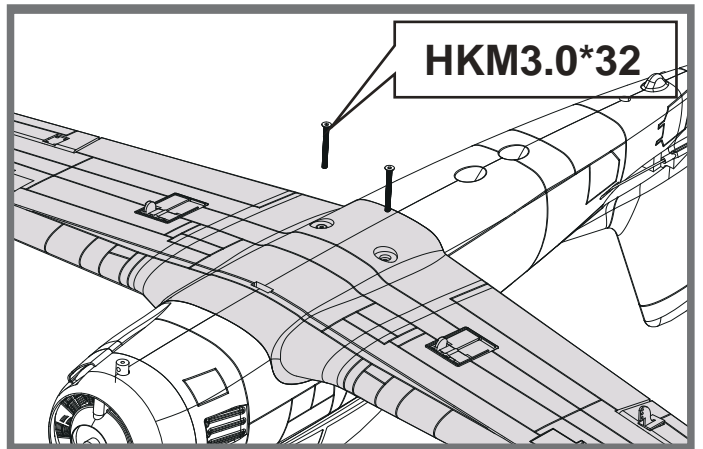

### 平尾安装

1.在图示平尾位置涂抹泡沫胶，将左右两侧平尾对准推入机身尾部槽位。注意：确保升降舵舵面朝下。

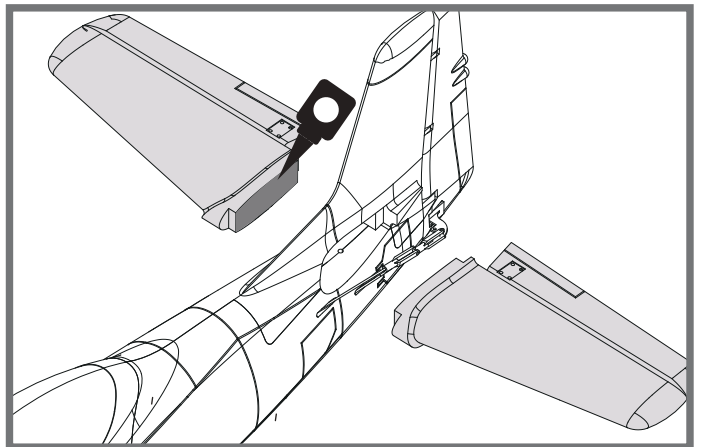
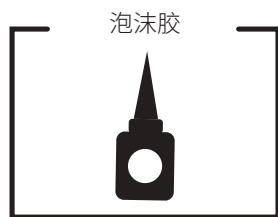

## 机体安装

2.保持平尾舵机在回中状态，安装U型夹至平尾舵角。

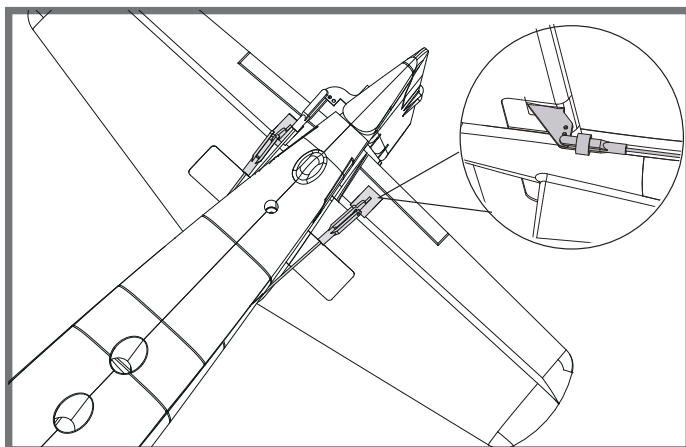

### 主起落架安装

- 1.打开主翼底部的起落架底座锁扣，如图将主起落架钢丝对准插入底座孔位（请勿将左、右起落架装反）。
- 2.扣合底座锁扣，主起落架组安装完成。

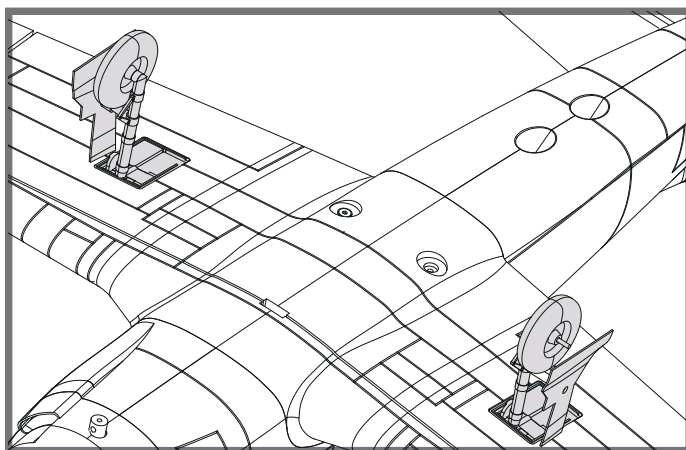
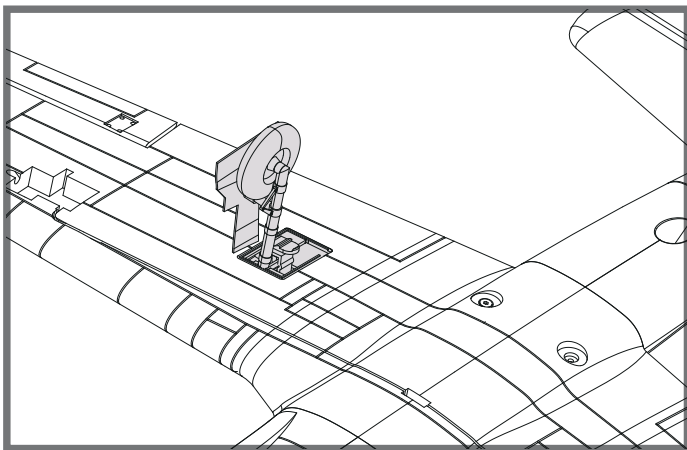
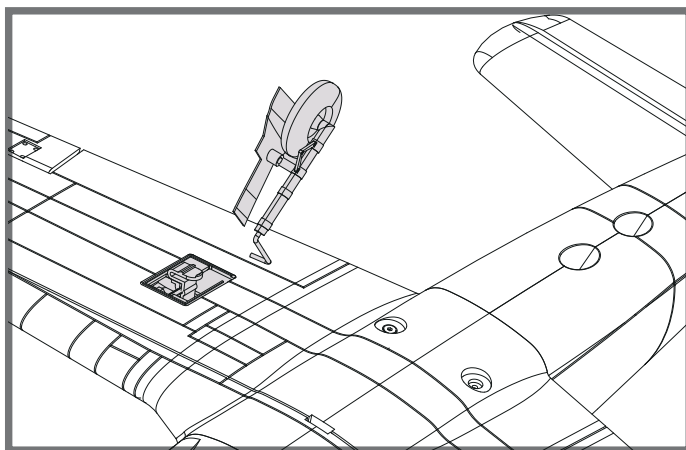

## 前起落架安装

如图所示，将前起落架插入机身底部相对应的槽位，使用机米螺丝3\*3拧紧即可。

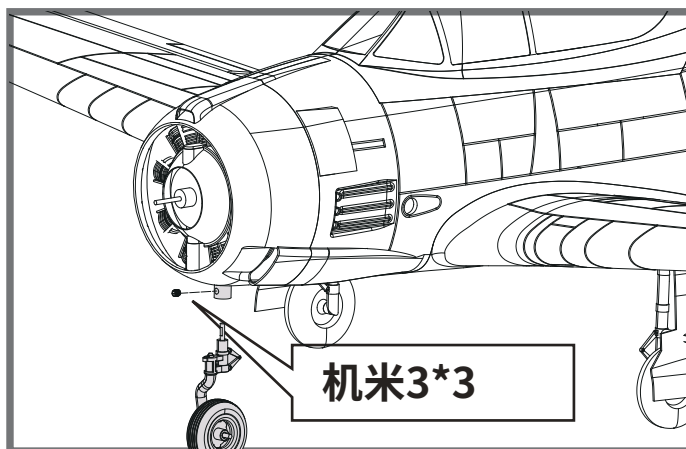

## 螺旋桨安装

1. 如图依序安装桨罩背板、螺旋桨、垫圈和桨罩紧固件。
2. 拧紧桨罩紧固件，直至螺旋桨牢固固定。

注意：电机的转动方向应该是顺时针方向（机体后方视角）。按照相反的顺序拆卸。

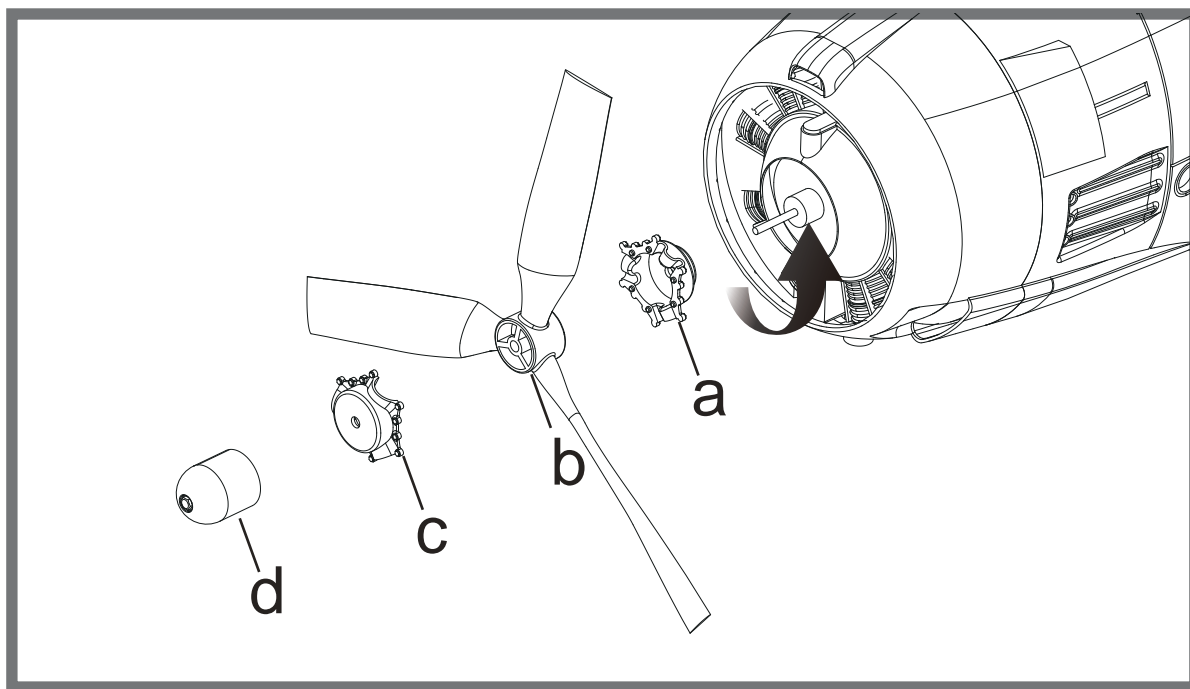

## 电池安装

1. 移开电池盖。
2. 取下电池板上的魔术贴(毛面)贴于电池上面。
3. 如图所示,将电池置于电池舱内,用魔术带绑紧,使有电源线的那端朝向飞机的尾部。

注意:由于不同电池厂家生产的电池重量有轻微的差异,需要调整电池的前后位置来平衡飞机的重心位置。

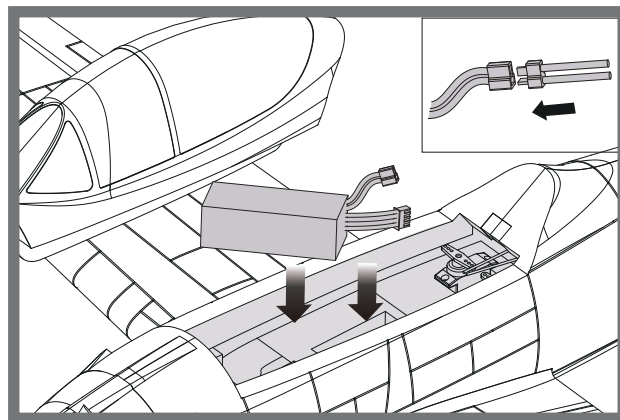

## 接收机连接示意图

如图所示,以Futaba遥控器为例,将舵机信号线按照图示顺序插入接收机通道,将所有连接线整理整齐并固定在电池舱后部的凹槽里,随后固定好接收机。请注意,如产品配有LED,则LED信号线可插入任何闲置通道。

		Receiver
副翼	1	Channel-1 — Aile
平尾	2	Channel-2 — Elev
油门	3	Channel-3 — Thro
垂尾	4	Channel-4 — Rudd
起落架	5	Channel-5 — Gear
襟翼	6	Channel-6 — Flap

## 遥控器设置

警告:为保证安全,在遥控器参数设置及舵面调整过程中,请务必拆下螺旋桨,以免电机意外启动发生事故。遥控器发射机开机前,确保油门杆在最低位置,其它摇杆在中立位置。开发射机并给接收机通电,随后听到电调初始化音(音符释义见后文“电子调速器说明书”)。观察所有舵面是否回中,如果没有回中,尽量通过调整舵机摇臂角度、连杆长度的方式来使舵面回中,若调整长度在安全范围内仍未回中,则使用遥控器通道微调或者菜单中的“SubTrim”选项来使舵面归中。如下图所示观察摇杆动作与舵面动作的对应关系,如发生舵面反向需要使用遥控器中的通道反向功能来纠正。

1. 移动发射器上的控制杆位置,确保舵面可以自如移动。

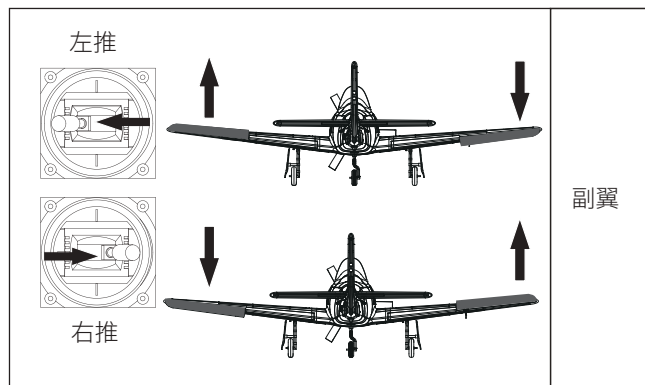

## 遥控器设置

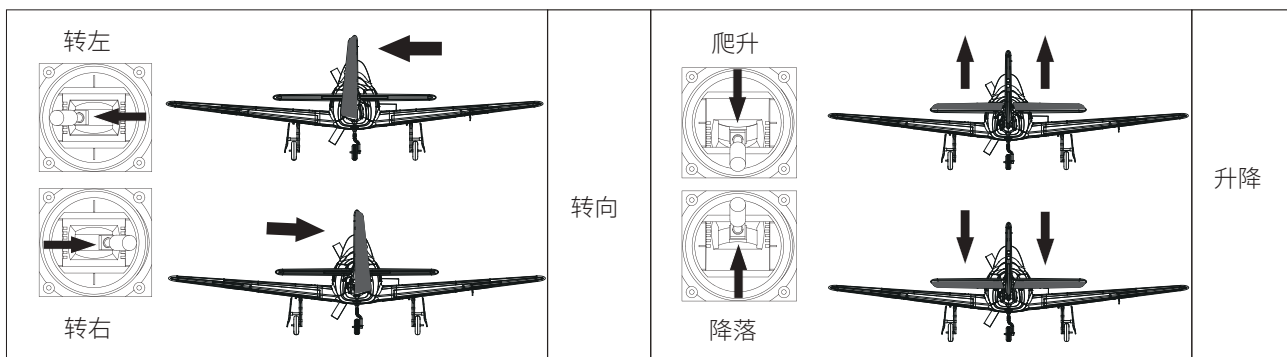

### 推荐舵面行程

温馨提示: 首飞建议用小舵面行程

	大	小
升降舵	16mm 上/下	12mm 上/下
副翼舵	14mm 上/下	10mm 上/下
方向舵	22mm 左/右	16mm 左/右

## 夹头安装方式

1. 保证舵机为回中状态, 将连接杆夹头调整到合适位置。
2. 将 O 型圈移开, 打开夹头, 将夹头安装到舵角孔位。
3. 将 O 型圈移回相应位置, 锁紧夹头。

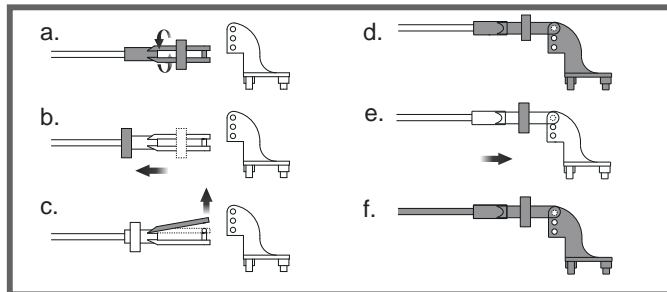

## 舵角和舵机摇臂安装

图示是舵角和舵面摇臂的出厂设置。首飞建议用出厂设置的小舵角飞行。首飞后, 可按图调整舵角。

	舵角	摇臂	大舵面
平尾			
垂尾			
副翼			
			小舵面

## 重心调整

通过移动电池在电池舱内的前后位置调整飞机的重心,使飞机保持水平或稍微头重的状态。首飞以后,重心位置可以根据你自己的飞行偏好再做更改。

- 1.如图所示,推荐重心位置是机翼前缘往后 45mm 处(安装电池以后)。推荐把食指放在机翼下面的重心位置来帮助调整重心。
- 2.在调整飞机重心时请确定飞机处于组装完毕待飞的状态。

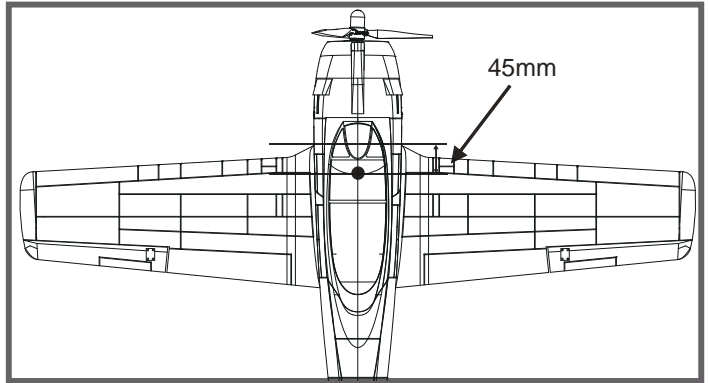

## 飞行前准备

### 起飞前的检查

每次飞行前须做严格的地面检查,可有效避免飞行事故的发生。

1. 检查全机螺丝是否安装到位、舵角摇臂连接可靠。机翼快拆装置已锁紧。
2. 安装电池,并调整飞机重心到说明书推荐位置。
3. 动力电池、遥控器发射机电池等已充满电,处于可靠工作状态。
4. 发射机油门杆保持在最低位(推荐使用带有油门锁定功能的遥控设备),打开发射机,随后连接动力电池,待电调初始化完成后检查各个舵面是否回中,是否动作正确。
5. 轻推油门观察螺旋桨转向是否正确。

所有检查完成后,方可进行飞行,初学者首次飞行需要有经验的爱好者协助完成,避免因操作不当发生飞行事故。

### 合适的飞行场地

航模飞行须远离人群、建筑物、树木、高压线及禁飞区的空旷场地(至少 2-3 个足球场大小)。初学者飞行前需要向有经验的爱好者询问相关安全事宜。

### 关于飞行时间

厂家推荐的飞行时间是使用厂家推荐型号的电池,由有经验的爱好者在微风天完成飞行测试得到的飞行时间,该时间与电池参数、飞机全备重量、飞行条件以及飞行手法相关,不同飞行条件可能得到不同的飞行时间。

建议爱好者在飞行时使用遥控器的“计时功能”,建议初始飞行时间设定为 4 分钟,飞行时间倒计时告警后,降落飞机并测量电池电压,方可估算飞行时间并重新调整遥控器计时。如发射机没有计时功能,需要其他设备辅助测算飞行时间,以保证飞行安全。在电池放电后期,禁止将飞机飞入下风区(风向指向的远端),防止动力不足而导致飞机不能安全返航。

## 故障检修指导

问题	问题原因	解决方式
油门推杆无响应, 但舵机有响应	<ul style="list-style-type: none"> <li>— 电调未连接电机</li> <li>— 油门通道反向</li> </ul>	<ul style="list-style-type: none"> <li>— 降低油门推杆和油门微调设定</li> <li>— 反过来重新装油门通道</li> </ul>
桨的噪音过大或者震动过大	<ul style="list-style-type: none"> <li>— 桨罩、桨、电机、电机架坏了</li> <li>— 桨或者桨罩的小部件松动了</li> <li>— 桨装反了</li> </ul>	<ul style="list-style-type: none"> <li>— 更换损坏的配件</li> <li>— 把桨、桨夹和桨罩的小部件拧紧</li> <li>— 反过来重新装桨</li> </ul>
飞行时间变短, 飞机无力	<ul style="list-style-type: none"> <li>— 电池电量低</li> <li>— 桨装反了</li> <li>— 电池坏了</li> </ul>	<ul style="list-style-type: none"> <li>— 重新给电池充电</li> <li>— 依照电池说明书更换新的电池</li> </ul>
飞舵面不动, 或者动作响应较慢	<ul style="list-style-type: none"> <li>— 舵面、舵角、连接杆、舵机坏了</li> <li>— 连接线坏了或者接头松了</li> </ul>	<ul style="list-style-type: none"> <li>— 更换或者维修坏了的配件</li> <li>— 检查所有连接线, 确保所有接头无松动现象</li> </ul>
舵面反向	<ul style="list-style-type: none"> <li>— 遥控器发射机通道反向</li> </ul>	<ul style="list-style-type: none"> <li>— 检查通道控制 (舵面) 方向, 调试飞机舵面和遥控器的舵面控制杆</li> </ul>
电机无力	<ul style="list-style-type: none"> <li>— 电机或电池坏了</li> <li>— 电调用了不合适的低压保护装置</li> </ul>	<ul style="list-style-type: none"> <li>— 检查电池、发射机、接收机、电调、电机是否有损坏 (如有, 请及时更换)</li> <li>— 立刻操控飞机降落, 重新给电池充电</li> </ul>
接收器的 LED 灯慢闪	<ul style="list-style-type: none"> <li>— 接收器低电量</li> </ul>	<ul style="list-style-type: none"> <li>— 检查电调和接收器之间的连接</li> <li>— 检查舵机是否受损</li> <li>— 检查连接杆是否安装到位</li> </ul>

## 配件列表

FMSPA101RED-1	机身	FMSPROP038	桨
FMSPA102RED-1	主翼	FMSDIX012	电机架
FMSPA103RED-1	平尾	PRKVX1700-1	3015-KV1700电机
FMSPA104RED	座舱组	PRESC004	20A电调
FMSPA105	桨罩	FMSSE005	9g 塑胶数码正向舵机
FMSPA107RED	机头罩	FMSSE011	9g 塑胶数码舵机 54 度
FMSPA108RED	主起落架组		
FMSPA109RED	前起落架组		
FMSPA110	连接杆		
FMSPA112RED	贴纸		

如需查找产品图片, 请登录FMS官方淘宝店<https://fmsmodel.taobao.com>。如需查找电调说明书, 则在以上网址搜索栏中搜索关键词“电调”, 即可在任何一款电调产品页面查看。